

**Outstanding cost-performance.**

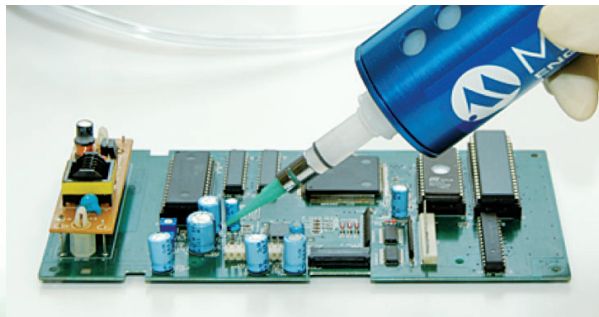

- 130% Improved dispensing accuracy.
- Equipped dispensing parameter setup function.
- Ultralight and compact.

Great cost-performance

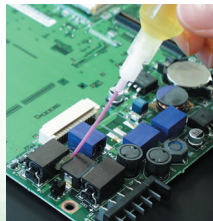

**DISPENSING APPLICATIONS**

Sealant dispensing for reinforcement of SMT components

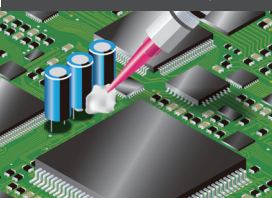

PCB coating

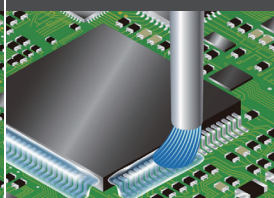

UV glue dispensing to Optical pickup



Grease dispensing on the switch of instrument panel

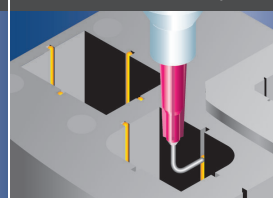

Magnet bonding on small-sized motor

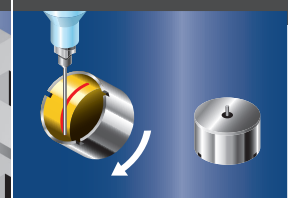

## Features

- Equipped with wide-range dispense timer
- Enable to switch any specification of output signal
- Universal input for worldwide voltage
- CE-marking, EU RoHS2 compliant

## Specifications

Product name		Highly functional ECO Dispenser SMART SHOT	
Model	MS-1-CTR	MS-1D-CTR	
Dispensing system	Air-pulse system		
Control system	Micro-computer controlled electronic-pneumatic system		
Pressure display	Analog pressure gauge	Digital pressure gauge	
Dispensing modes	TIMED/MANUAL mode		
Dispensing pressure setting range	20 to 700 kPa		
Dispensing time setting range	0.010 to 9,999 s		
Vacuum pressure setting range	0 to -20 kPa (Source pressure 600 kPa)		
Main functions	Manual/Timed mode switching, Stopwatch		
Input signals	Dispensing		
Output signals	Dispensing completion/in-dispensing (selectable)		
Source pressure	Connection pecifications	One-touch joint for OD6mm	
	Range	Dispensing pressure +100 kPa or more and maximum of 800 kPa	
Rated power supply and frequency	AC100 to 240 V 50/60 Hz		
Power consumption	12 W		
Conformity standards	EU RoHS2, CE-marking (Low Voltage Directive, EMC Directive)		
External dimensions	W142 x D138.5 x H103 mm		
Weight	0.79 kg		
Other options	Handy switch, Foot switch, Syringe stand, Various connection cables, etc.		

## External dimensions

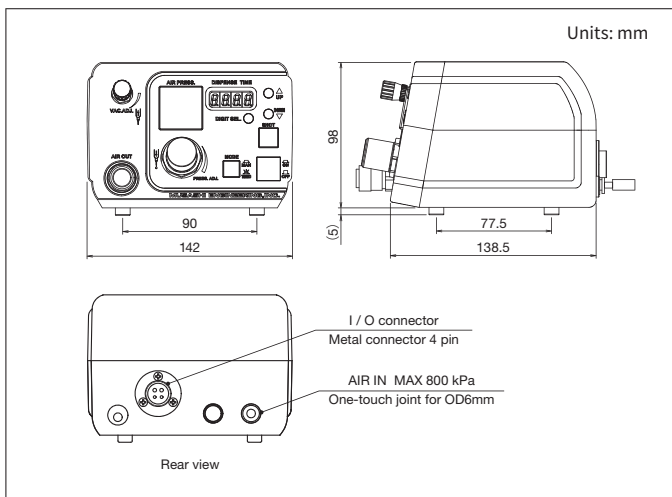

## Applicable dispensing materials

Various fluids such as solder paste, silver paste, UV resin, epoxy resin, instant adhesive, silicone resin and grease.

## Applications

Dispensing adhesives, potting, coating, sealing, filling, dotting and drawings.

### Convenient option



### Handy switch

Handy switches that is fit on the tip of syringe to control dispensing ON/OFF for manual application. The soft touch switch operation offers precise dispensing control and less nozzle off-target.

Model: ① LS-3T-1604P  
② LS-2T-1604P



### Foot switch

This switch is used to trigger and stop dispensing with your foot.

Model: FS/W-2-1604P



### Handy switch compatible Syringe stand

These stands are used for holding the syringe during and after operation. Please choose according to the syringe size you are using.

Model: ① SYS-5B for 5 mL  
② SYS-10B for 10 mL  
③ SYS-20B for 20 mL  
④ SYS-30B for 30 mL  
⑤ SYS-50B for 50 mL



#### Safety precautions

Please read the instruction manual carefully before use to ensure correct and safe usage.

\*These specifications are subject to change without any notice.

\*The copyright of this catalog belongs to our company. Reproduction and distribution of the pictures, illustrations and any other information in this catalog to any other media without prior written permission are strictly prohibited; doing so will result in copyright infringement.

MUSASHI ENGINEERING, INC. (headquarters) is certified and registered according to the ISO 9001 Quality Management System and the ISO 14001 Environmental Management System.



World Leading Dispenser  
**MUSASHI ENGINEERING, INC.**

**SINGAPORE** 10 Ubi Crescent #05-24 Ubi Techpark Lobby B Singapore 408564  
TEL:(65)6258-2422 / FAX:(65)6258-4844

**HEAD OFFICE** 8-7-4, Shimorenjaku, Mitaka, Tokyo, 181-0013, Japan TEL:(81)422-76-7111 FAX:(81)422-76-7122

<http://www.musashi-engineering.co.jp/english/>

CAT. No. MS-1/1D-122110-E-COPY